



CMDSH-3F-RZ

**SURFACE MOUNT SILICON
SCHOTTKY DIODE
RUGGEDIZED PACKAGING**

DESCRIPTION:

The CENTRAL SEMICONDUCTOR CMDSH-3F-RZ is a silicon Schottky diode, manufactured in an SOD-323F surface mount package, designed for fast switching applications requiring a low forward voltage drop. It features a robust design manufactured specifically for operation in harsh environments where temperature and moisture may contribute to degraded performance and reliability.

UNIQUE DEVICE CONSTRUCTION FEATURES:

- Alloy 42 or pure copper lead frame
- Eutectic die attach
- Gold wire bond
- Pb/Sn lead plating available

MARKING CODE: S1F
MAXIMUM RATINGS: ($T_A=25^\circ\text{C}$ unless otherwise noted)

	SYMBOL		UNITS
Peak Repetitive Reverse Voltage	V_{RRM}	30	V
Average Forward Current	I_O	100	mA
Peak Forward Surge Current, $t_p=10\text{ms}$	I_{FSM}	750	mA
Power Dissipation	P_D	225	mW
Operating and Storage Junction Temperature	T_J, T_{stg}	-65 to +150	$^\circ\text{C}$
Thermal Resistance	θ_{JA}	556	$^\circ\text{C/W}$

ELECTRICAL CHARACTERISTICS: ($T_A=25^\circ\text{C}$)

SYMBOL	TEST CONDITIONS	MIN	TYP	MAX	UNITS
I_R	$V_R=25\text{V}$			1.0	μA
BV_R	$I_F=100\mu\text{A}$	30			V
V_F	$I_F=2.0\text{mA}$		0.29		V
V_F	$I_F=15\text{mA}$		0.37		V
V_F	$I_F=50\text{mA}$		0.44	0.55	V
V_F	$I_F=100\text{mA}$		0.51	0.80	V
C_J	$V_R=1.0\text{V}, f=1.0\text{MHz}$		7.0		pF

R0 (16-April 2026)

CMDSH-3F-RZ

**SURFACE MOUNT SILICON
SCHOTTKY DIODE
RUGGEDIZED PACKAGING**

SOD-323F CASE - MECHANICAL OUTLINE

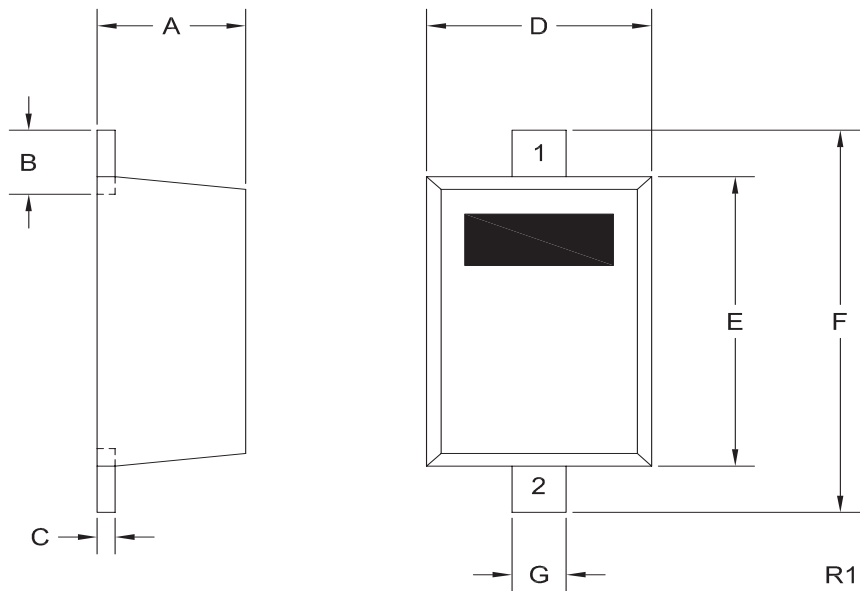

LEAD CODE:

- 1) Cathode
- 2) Anode

MARKING CODE: S1F

DIMENSIONS				
SYMBOL	INCHES		MILLIMETERS	
	MIN	MAX	MIN	MAX
A	0.028	0.035	0.70	0.90
B	0.012	-	0.30	-
C	0.002	0.006	0.05	0.15
D	0.045	0.053	1.15	1.35
E	0.069	0.077	1.75	1.95
F	0.091	0.106	2.30	2.70
G	0.010	0.014	0.25	0.35
SOD-323F (REV:R1)				

R0 (16-April 2026)

CMDSH-3F-RZ
SURFACE MOUNT SILICON
SCHOTTKY DIODE
RUGGEDIZED PACKAGING

TYPICAL ELECTRICAL CHARACTERISTICS

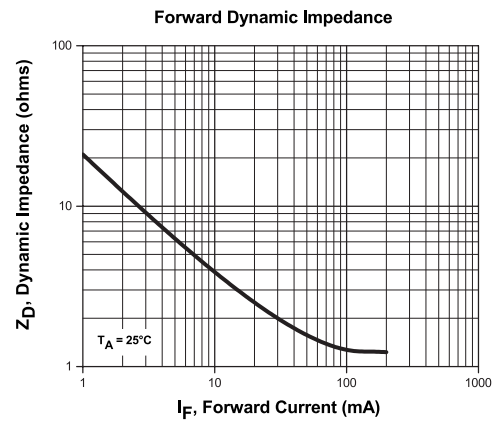
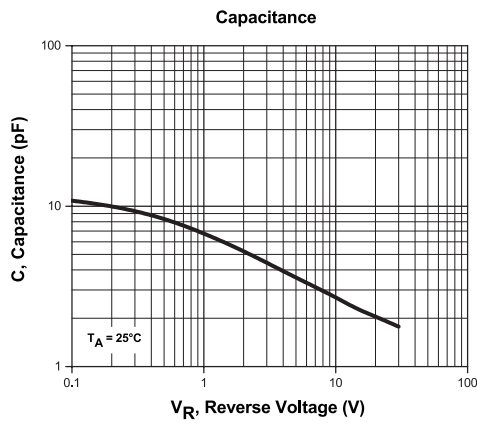
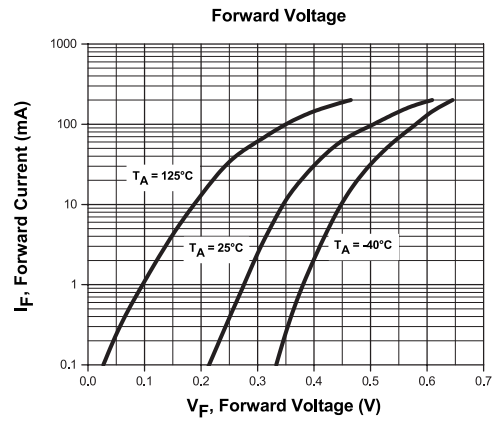
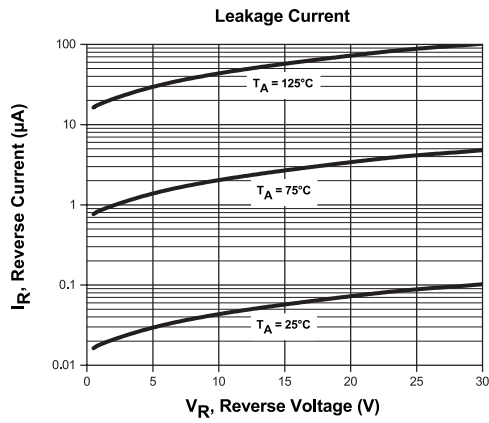

R0 (16-April 2026)

CMDSH-3F-RZ

**SURFACE MOUNT SILICON
SCHOTTKY DIODE
RUGGEDIZED PACKAGING**

TYPICAL ELECTRICAL CHARACTERISTICS

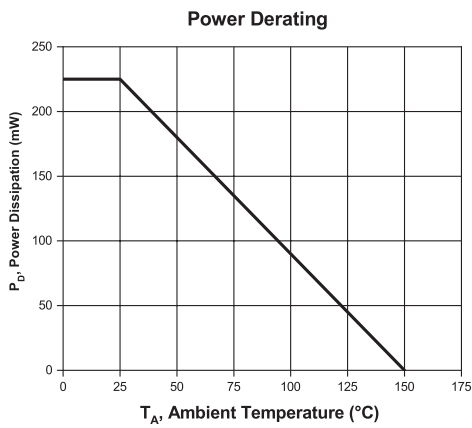
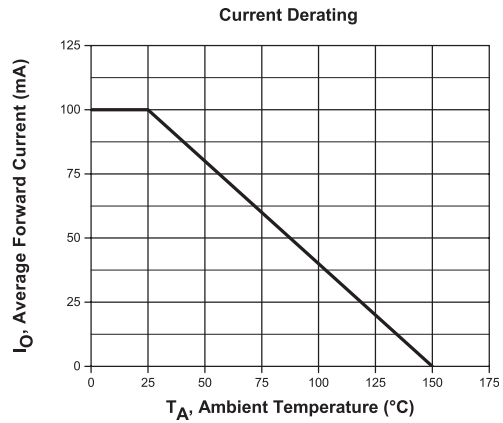
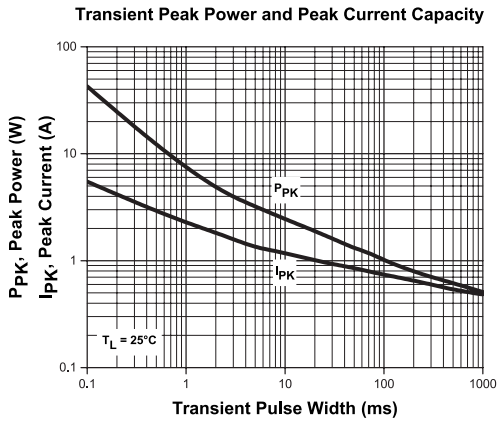

R0 (16-April 2026)