

CLL4728A THRU CLL4764A

**SURFACE MOUNT
SILICON ZENER DIODE
1 WATT, 3.3 THRU 100 VOLTS**



www.centrasemi.com

DESCRIPTION:

The CENTRAL SEMICONDUCTOR CLL4728A Series Silicon Zener Diode is a high quality voltage regulator for use in surface mount industrial, commercial, entertainment and computer applications.

MARKING: CATHODE BAND



MELF CASE

MAXIMUM RATINGS: ($T_A=25\text{ }^\circ\text{C}$)

Power Dissipation
Operating and Storage Junction Temperature
 V_Z Tolerance: Part number with "A" suffix
 V_Z Tolerance: Part number with "C" suffix
 V_Z Tolerance: Part number with "D" suffix

SYMBOL

P_D 1.0
 T_J, T_{stg} -65 to +200
 ± 5
 ± 2
 ± 1

UNITS

W
 $^\circ\text{C}$
%
%
%

ELECTRICAL CHARACTERISTICS: ($T_A=25\text{ }^\circ\text{C}$) $V_F=1.2\text{MAX @ } I_F=200\text{mA}$ (for all types)

TYPE	ZENER VOLTAGE	TEST CURRENT	MAXIMUM ZENER IMPEDANCE			MAXIMUM REVERSE CURRENT		MAXIMUM CURRENT
	$V_Z @ I_{ZT}$	I_{ZT}	$Z_{ZT} @ I_{ZT}$	$Z_{ZK} @ I_{ZK}$		$I_R @ V_R$		I_{ZM}
	V	mA	Ω	Ω	mA	μA	V	mA
CLL4728A	3.3	76	10	400	1.0	100	1.0	1380
CLL4729A	3.6	69	10	400	1.0	100	1.0	1260
CLL4730A	3.9	64	9.0	400	1.0	50	1.0	1190
CLL4731A	4.3	58	9.0	400	1.0	10	1.0	1070
CLL4732A	4.7	53	8.0	500	1.0	10	1.0	970
CLL4733A	5.1	49	7.0	550	1.0	10	1.0	890
CLL4734A	5.6	45	5.0	600	1.0	10	2.0	810
CLL4735A	6.2	41	2.0	700	1.0	10	3.0	730
CLL4736A	6.8	37	3.5	700	1.0	10	4.0	660
CLL4737A	7.5	34	4.0	700	0.5	10	5.0	605
CLL4738A	8.2	31	4.5	700	0.5	10	6.0	550
CLL4739A	9.1	28	5.0	700	0.5	10	7.0	500
CLL4740A	10	25	7.0	700	0.25	10	7.6	454
CLL4741A	11	23	8.0	700	0.25	5.0	8.4	414
CLL4742A	12	21	9.0	700	0.25	5.0	9.1	380
CLL4743A	13	19	10	700	0.25	5.0	9.9	344
CLL4744A	15	17	14	700	0.25	5.0	11.4	304
CLL4745A	16	15.5	16	700	0.25	5.0	12.2	285
CLL4746A	18	14	20	750	0.25	5.0	13.7	250
CLL4747A	20	12.5	22	750	0.25	5.0	15.2	225
CLL4748A	22	11.5	23	750	0.25	5.0	16.7	205
CLL4749A	24	10.5	25	750	0.25	5.0	18.2	190
CLL4750A	27	9.5	35	750	0.25	5.0	20.6	170
CLL4751A	30	8.5	40	1000	0.25	5.0	22.8	150

CLL4728A THRU CLL4764A

SURFACE MOUNT
SILICON ZENER DIODE
1 WATT, 3.3 THRU 100 VOLTS



ELECTRICAL CHARACTERISTICS - Continued: ($T_A=25^\circ\text{C}$) $V_F=1.2\text{MAX}$ @ $I_F=200\text{mA}$ (for all types)

TYPE	ZENER VOLTAGE	TEST CURRENT	MAXIMUM ZENER IMPEDANCE			MAXIMUM REVERSE CURRENT		MAXIMUM CURRENT
	$V_Z @ I_{ZT}$	I_{ZT}	$Z_{ZT} @ I_{ZT}$	$Z_{ZK} @ I_{ZK}$		$I_R @ V_R$		I_{ZM}
	V	mA	Ω	Ω	mA	μA	V	mA
CLL4752A	33	7.5	45	1000	0.25	5.0	25.1	135
CLL4753A	36	7.0	50	1000	0.25	5.0	27.4	125
CLL4754A	39	6.5	60	1000	0.25	5.0	29.7	115
CLL4755A	43	6.0	70	1500	0.25	5.0	32.7	110
CLL4756A	47	5.5	80	1500	0.25	5.0	35.8	95
CLL4757A	51	5.0	95	1500	0.25	5.0	38.8	90
CLL4758A	56	4.5	110	2000	0.25	5.0	42.6	80
CLL4759A	62	4.0	125	2000	0.25	5.0	47.1	70
CLL4760A	68	3.7	150	2000	0.25	5.0	51.7	65
CLL4761A	75	3.3	175	2000	0.25	5.0	56	60
CLL4762A	82	3.0	200	3000	0.25	5.0	62.2	55
CLL4763A	91	2.8	250	3000	0.25	5.0	69.2	50
CLL4764A	100	2.5	350	3000	0.25	5.0	76	45

MELF CASE - MECHANICAL OUTLINE

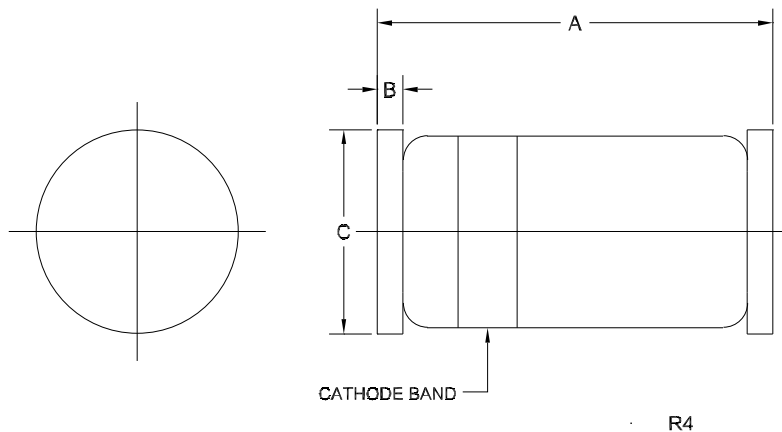

MARKING: CATHODE BAND

DIMENSIONS				
SYMBOL	INCHES		MILLIMETERS	
	MIN	MAX	MIN	MAX
A	0.185	0.217	4.70	5.50
B	0.012	0.022	0.30	0.56
C (DIA)	0.094	0.115	2.40	2.92

MELF (REV:R4)

R5 (21-July 2023)

Package Details

MELF Case



Mechanical Drawing

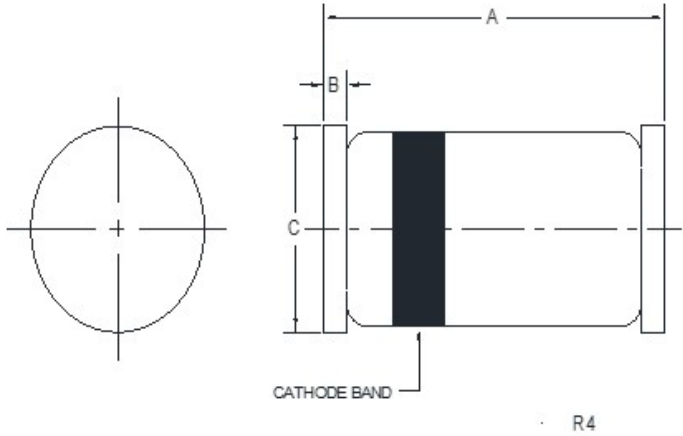

DIMENSIONS				
SYMBOL	INCHES		MILLIMETERS	
	MIN	MAX	MIN	MAX
A	0.185	0.217	4.70	5.50
B	0.012	0.022	0.30	0.56
C (DIA)	0.094	0.115	2.40	2.92
MELF (REV:R4)				

Part Marking: Cathode Band

Mounting Pad Geometry (Dimensions in mm)

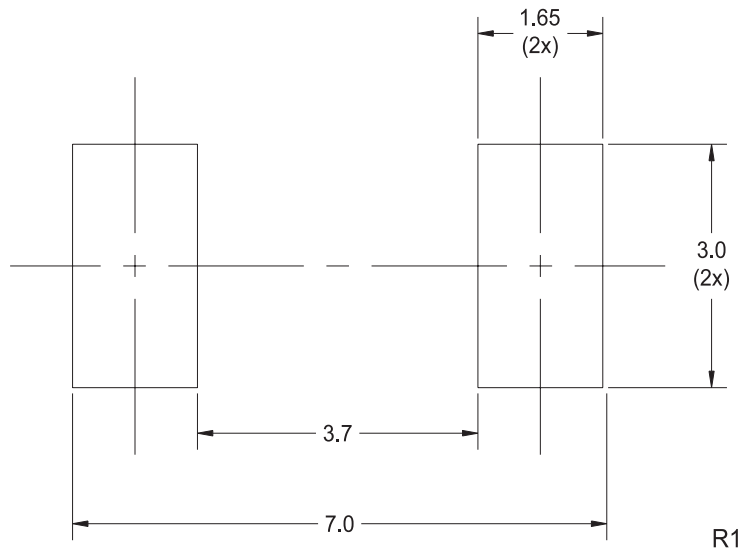

R3 (28-June 2023)

Package Details

MELF Case



Tape Dimensions and Orientation (Dimensions in mm)

Tape Width: 12mm

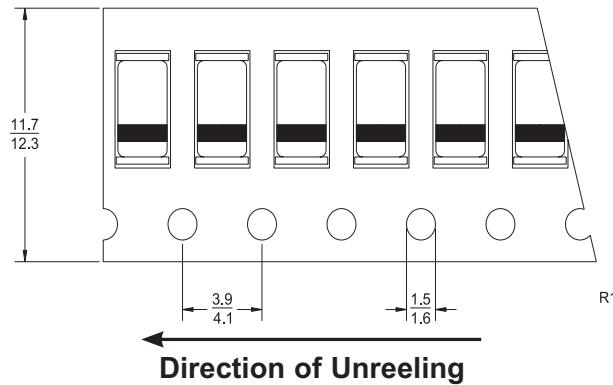

Devices are taped in accordance with Electronic Industries Association Standard EIA-481-1-A

Packaging Base

7" Reel = 1,500 pcs.

Reel Labeling Information

Each reel is labeled with the following information:

Central Part Number, Customer Part Number, Purchase Order Number, Quantity, Lot Number, Date Code and Ship Date.

Reel Packing Information

Reel Size	Reels per Box (Maximum)	Parts per Box (Maximum)	Box Dimensions		Shipping Weight (Max.)	
			INCH	CM	LB	KG
7"	6	9,000	9x9x5	23x23x13	6	3
	13	19,500	9x9x9	23x23x23	11	5
	32	48,000	21x9x9	53x23x23	27	13
	82	123,000	27x9x17	69x23x43	68	31

Ordering Information

- For devices taped and reeled on 7" reels, add TR suffix to part number.
- All SMDs are available in small quantities for prototype and manual placement applications.

R3 (28-June 2023)

Material Composition Specification

MELF Case



Device average mass 150 mg
 Fluctuation margin +/-10%

Component	Material	Material		Substance	CAS No.	Substance		
		(%wt)	(mg)			(%wt)	(mg)	(ppm)
active device	doped Si	0.17%	0.25	Si	7440-21-3	0.17%	0.25	1,667
leadframe	Fe alloy	62.67%	94	Fe	7439-89-6	27.73%	41.6	277,333
				Ni	7440-02-0	24.6%	36.9	246,000
				Cu	7440-50-8	10.33%	15.5	103,333
encapsulation	glass	36.4%	54.6	Pb	7439-92-1	20%	30	200,000
				O	7782-44-7	8.73%	13.1	87,333
				Si	7440-21-3	6.67%	10	66,667
				K	7440-09-7	1.0%	1.5	10,000
plating*	tin/lead process	0.77%	1.15	Sn	7440-31-5	0.61%	0.92	6,133
				Pb	7439-92-1	0.15%	0.23	1,533
	matte tin	0.77%	1.15	Sn	7440-31-5	0.77%	1.15	7,667

*For Lead Free plating, add suffix "PB FREE" to part number.
 For Tin/Lead plating, add suffix "TIN/LEAD" to part number.
 No suffix designation allows for the supply of either lead-free or tin/lead plated product depending on availability.

Disclaimer

The information provided in this Material Composition data sheet is, to the best of our knowledge, correct. However, there is no guarantee to completeness or accuracy, as some information is derived from data sources outside the company.

R5 (16-July 2018)